

For Steel Wire Size	35-50 mm ²	
For Steel Wire Diameter	7.5-9.0 mm	
Clamps Required	For steel wire size 35mm ²	2 Pcs.
	For steel wire size 50mm ²	3 Pcs.
Material	U-Bolt and nut	Steel
	Body	Malleable cast iron or mild steel
Tightening torque of u-bolt	Min. 2 kg-m.	
Slip strength for steel wire 50mm ²	Min. 3,020 kg.	
Surface Finishing	Hot dip galvanized to according to PEA standard.	
Weight	9.4 kg /100 Pcs.	

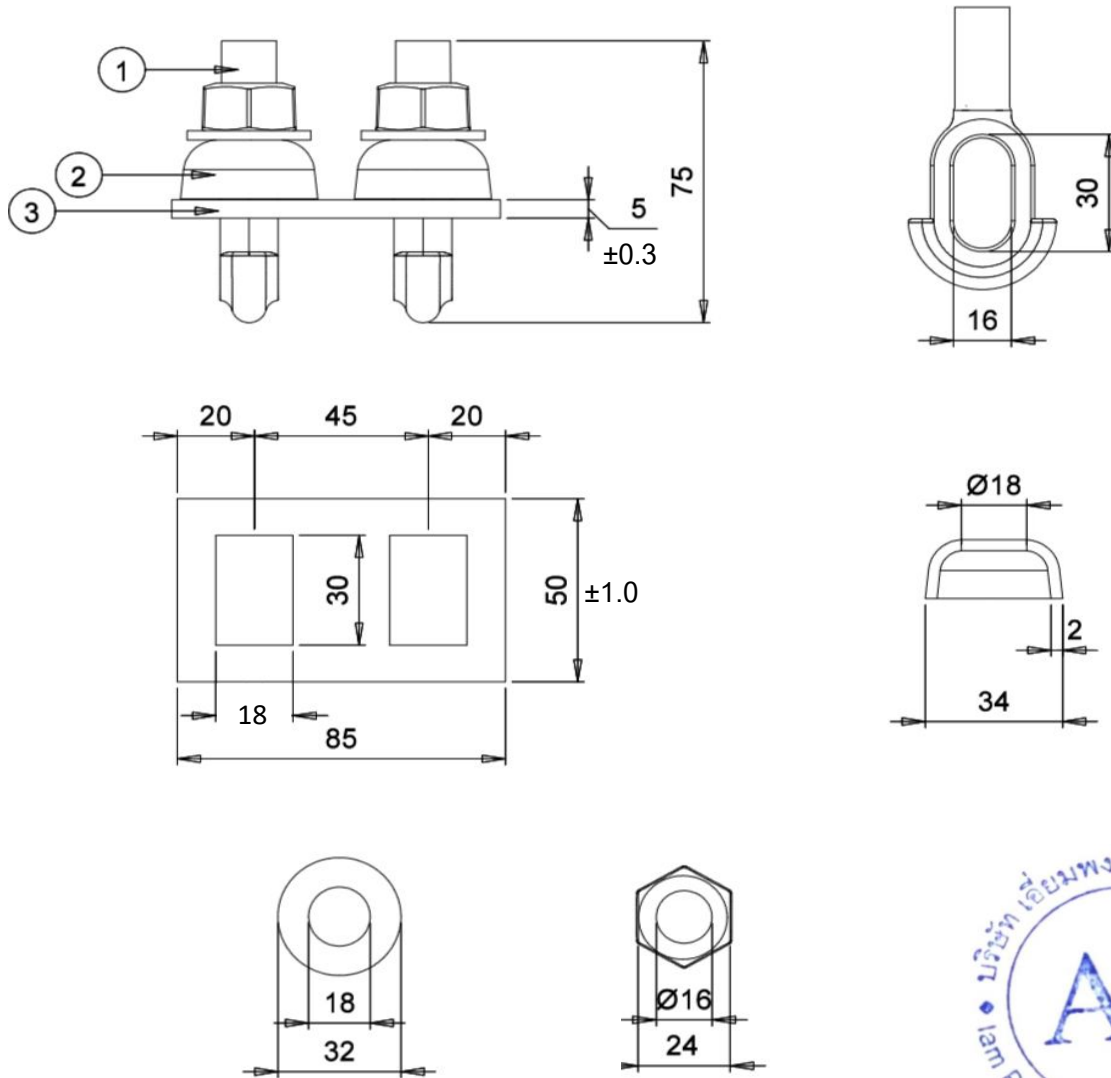

	บริษัท เอี่ยมพงศ์พัฒนา จำกัด IAMPONG DEVELOPMENT CO.,LTD	Approved by  _____ Managing Director
	PEA Material No. 1010230000	ยูแคล้มป์ สลักเดี่ยว เอ็ม 8 Clamp, Single U-Bolt, M8



For Steel Wire Size	95 mm ²
For Steel Wire Diameter	7.5-9.0 mm
Clamps Required for attaching to guy wire end	2 set.
Material	Mild Steel
Slip strength for steel wire 95mm ²	Min. 5,000 kg.
Surface Finishing	Hot dip galvanized to according to PEA standard.



บริษัท เอี่ยมพงศ์พัฒนา จำกัด
IAMPONG DEVELOPMENT CO.,LTD

Approved by

Managing Director

PEA Material No.

1010230001

แคลมป์ สลักห่วงคู่ เอ็ม 16

Clamp, Double Eye-Bolt, M16

Date : 12/2/63