

⚠ Table 1.Code Request.

HOLE SELECTION	
Code.No.	Hole Size
<input type="checkbox"/> KOH 400-12	14.3
<input type="checkbox"/> KOH 400-14	16
<input type="checkbox"/> KOH 400-16	17.5
<input type="checkbox"/> Other.....

01	Add Detail Table 1	21/06/19				
00	Add Dwg. CU (FG 03)	24/09/13	①	Body	Copper W/Tin Plating	1
Rev.	Revision note	Date	Part	Description	Material	Q'Ty
Filename SE-EN-19-147 TN 454 M/D:/HW/KOH 400-16		Scale 1:1	Title COPPER LUG 1 HOLE LONG BARREL			Dep. LPS
Designed by	Checked by	Approved by	Sheet 1	Dwg.No. KOH 400-XX-CU	Rev. 01	

Kumwell®

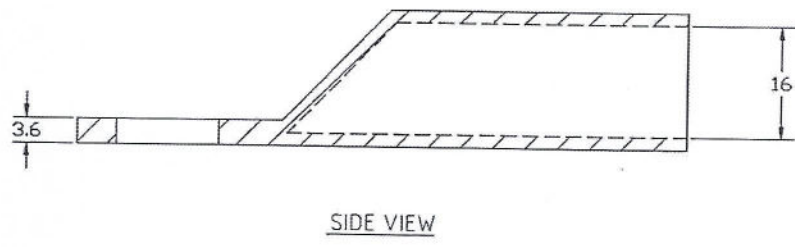
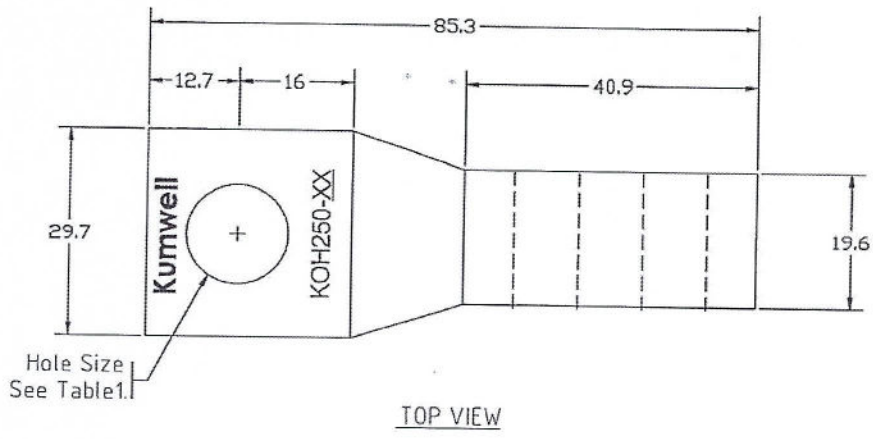

Table 1.Code Request.

Code No.	HOLE SELECTION	
	Stud Size	Hole Size
<input type="checkbox"/> KOH 250-10	3/8"/M10	11.2
<input type="checkbox"/> KOH 250-12	1/2"/M12	14.3
<input type="checkbox"/> KOH 250-14	M14	15.6
<input type="checkbox"/> Other.....	_____	_____

Note: Hole ϕ 14.3 mm.For Stud size 1/2"
By Manufacturing

ORIGINAL

02	Revised Form & Add Code "KOH 250-14"	29/3/56				
01	Revised Form	27/4/53				
00	New Design	17/4/52	①	Body	Copper W/Tin Plating	1
Rev.	Revision note	Date	Part	Description	Material	Q'Ty
Filename TN 25 M/D:/KML/LUG/KOH/KOH250-12.dwg		Scale 1:1	Title COPPER LUG 1 HOLE LONG BARREL		Dep. HW	
Designed by P.S. <input checked="" type="checkbox"/> J.O. <input checked="" type="checkbox"/>	Checked by P.P. <input checked="" type="checkbox"/> S.K. <input checked="" type="checkbox"/>	Approved by S.J./B.K. <input checked="" type="checkbox"/> <input checked="" type="checkbox"/>	Sheet 1	Dwg.No. KOH 250-XX-CU	Rev. 02	

Kumwell®

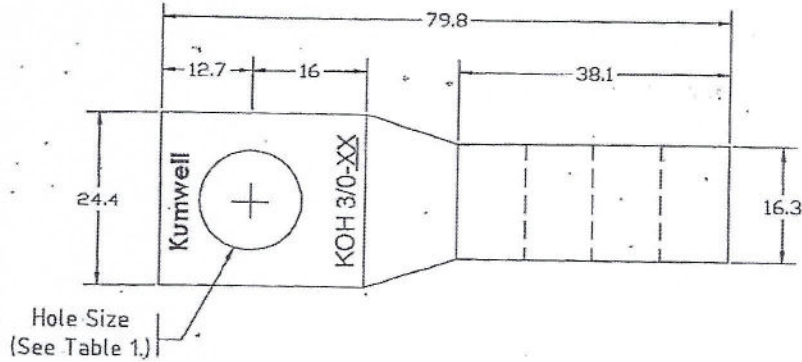

TOP VIEW

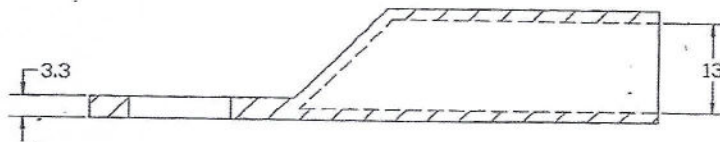

SIDE VIEW

Table 1.Code Request.

Code No.	HOLE SELECTION	
	Stud Size	Hole Size
<input type="checkbox"/> KOH 3/0-6	1/4"/M6	8
<input type="checkbox"/> KOH 3/0-8	5/16"/M8	9.6
<input type="checkbox"/> KOH 3/0-10	3/8"/M10	11.2
<input type="checkbox"/> KOH 3/0-12	1/2"/M12	14.3
<input type="checkbox"/> KOH 3/0-14	M14	15.6
<input type="checkbox"/> Other... <u>KOH 3/0-16</u>	<u>M16</u>	<u>17.5</u>

Note: Hole ϕ 14.3 mm. For Stud size 1/2"
By Manufacturing

ORIGINAL

00	Refer Dwg.FG Rev.03 & Add Code KOH 3/0-14	21/8/13	①	Body	Copper With Tin Plating	1
Rev.	Revision note	Date	Part	Description	Material.	Q'Ty
Filename TN 25 M/D:/KML/LUGS/KTH/KTH3/0-12.dwg		Scale 1:1	Title COPPER LUG 1 HOLE LONG BARREL			Dep. HW
Designed by P.S. <input checked="" type="checkbox"/> J.O. <input checked="" type="checkbox"/>	Checked by P.P. <input checked="" type="checkbox"/> S.K. <input type="checkbox"/>	Approved by S.J./B.K. <input checked="" type="checkbox"/>	Sheet 1	Dwg.No. KOH3/0-XX-CU		Rev. 00

Per

Kumwell®

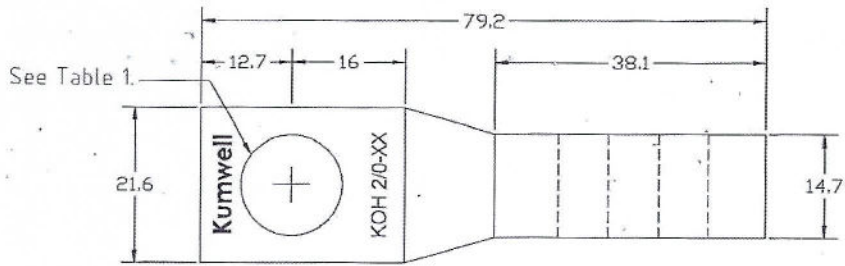

TOP VIEW

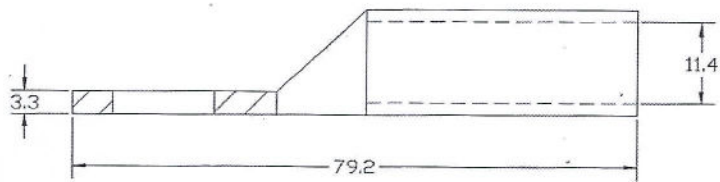

SIDE VIEW

Table 1. Code Request.

Code No.	HOLE SELECTION	
	Stud Size	Hole Size
<input type="checkbox"/> KOH 2/0-6	1/4"/M6	8
<input type="checkbox"/> KOH 2/0-8	5/16"/M8	9.6
<input type="checkbox"/> KOH 2/0-10	3/8"/M10	11.2
<input type="checkbox"/> KOH 2/0-12	1/2"/M12	14.3
<input type="checkbox"/> KOH 2/0-14	M14	15.6
<input type="checkbox"/> Other.....	_____	_____

Note: Hole ϕ 14.3 mm. For Stud size 1/2"
By Manufacturing

ORIGINAL

00	Refer Dwg.FG Rev.03 & Add Code KOH 2/0-14	21/8/13	①	Body	Copper W/Tin Plating	1
Rev.	Revision note	Date	Part	Description	Material	Q'Ty
Filename TN 25 M/D:/KML/LUG/KOH 2/0-XX.dwg		Scale 1:1	Title COPPER,LUG 1 HOLE LUNG BARREL			Dep. HW
Designed by P.S. <input checked="" type="checkbox"/> J.O. <input checked="" type="checkbox"/>	Checked by P.P. <input checked="" type="checkbox"/> S.K. <input type="checkbox"/>	Approved by S.J./B.K. <input checked="" type="checkbox"/>	Sheet 1	Dwg.No. KOH 2/0-XX-CU	Rev. 00	

For

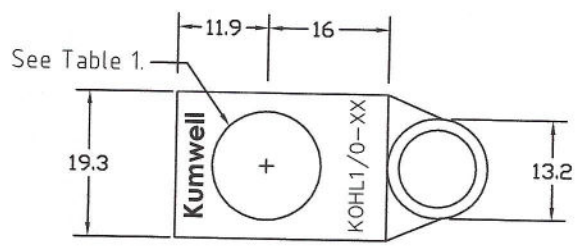

TOP VIEW

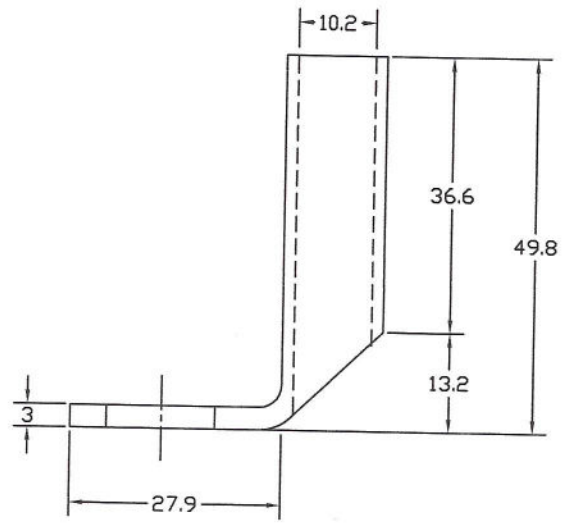

SIDE VIEW

Table 1.Code Request.

Code No.	HOLE SELECTION	
	Stud Size	Hole Size(D) (±0.2mm)
<input type="checkbox"/> KOHL 1/0-6	1/4"/M6	8
<input type="checkbox"/> KOHL 1/0-8	5/16"/M8	9.6
<input type="checkbox"/> KOHL 1/0-10	3/8"/M10	11.2
<input type="checkbox"/> KOHL 1/0-12	1/2"/M12	14.3
<input type="checkbox"/> Other.....

Note: Hole ϕ 14.3 mm.For Stud size 1/2"
By Manufacturing

ORIGINAL

00	Modify From Dwg. "KOH 1/0-XX"	19/05/18	①	Body	Tin plated copper	1
Rev.	Revision note	Date	Part	Description	Material	Q'Ty
Filename S:\NON-LPS\DWG LPS 3\COPPER LUG\KOHL 1/0-XX.dwg		Scale 1:1	Title COPPER LUG 1 HOLE LONG BARREL			Dep. LPS
Designed by C.B. <i>[Signature]</i>	Checked by J.O. <i>[Signature]</i>	Approved by <i>[Signature]</i>	Sheet 1	Dwg.No. KOHL 1/0-XX-CU	Rev. 00	