

PEA Material No. 1030130100

Material Mild Steel, Flat Iron 38x6 mm.

Mechanical Details

Allowable load "P" 500 Kp.

Allowable load "O" 120 Kp.

Surface Finishing Hot Dip Galvanized according to PEA standard.



บริษัท เอี่ยมพงศ์พัฒนา จำกัด  
IAMPONG DEVELOPMENT CO.,LTD

Approved by

Managing Director

PEA Material No.  
1030130100

ที่จับลูกกรอก สำหรับลูกกรอก (แร็คเดี่ยว)

Clevis, Flat Steel, For Insulator

Date : 4/01/64

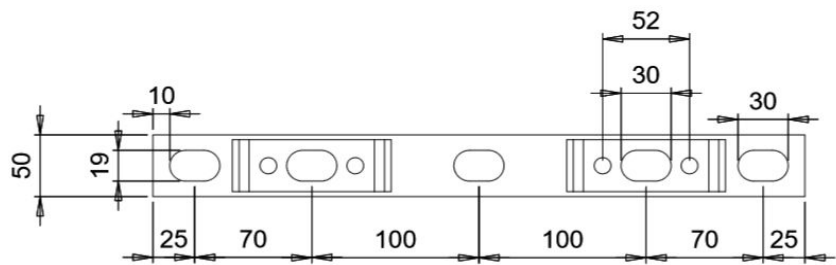
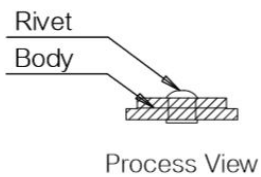
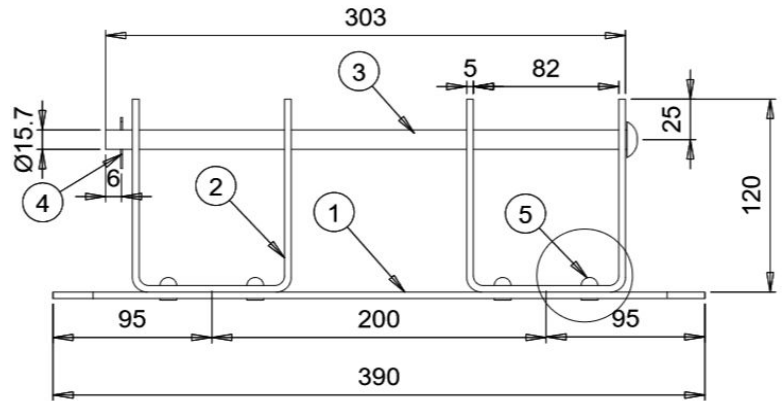
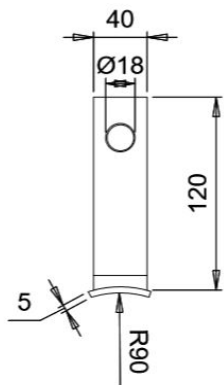

|                   |   |
|-------------------|---|
| PEA Material No.  | 1030130000                                    |
| Material of Body  | Flat Iron 50x5 mm.                            |
| Material of Bow   | Flat Iron 40x5 mm.                            |
| Bolt              | Ø 15.7 mm.                                    |
| Cotton Pin        | 4x30 mm.                                      |
| Rivet             | 10x26 mm.                                     |
| Surface Finishing | Hot Dip Galvanized according to PEA standard. |



บริษัท เอี่ยมพงศ์พัฒนา จำกัด  
IAMPONG DEVELOPMENT CO.,LTD

Approved by

Managing Director

PEA Material No.

1030130000

แร็ค 2x200 มม.(2x8") แบบหลังยื่น

Rack, Secondary, Medium Pressed Steel 2x200mm.

Date : 4/01/64

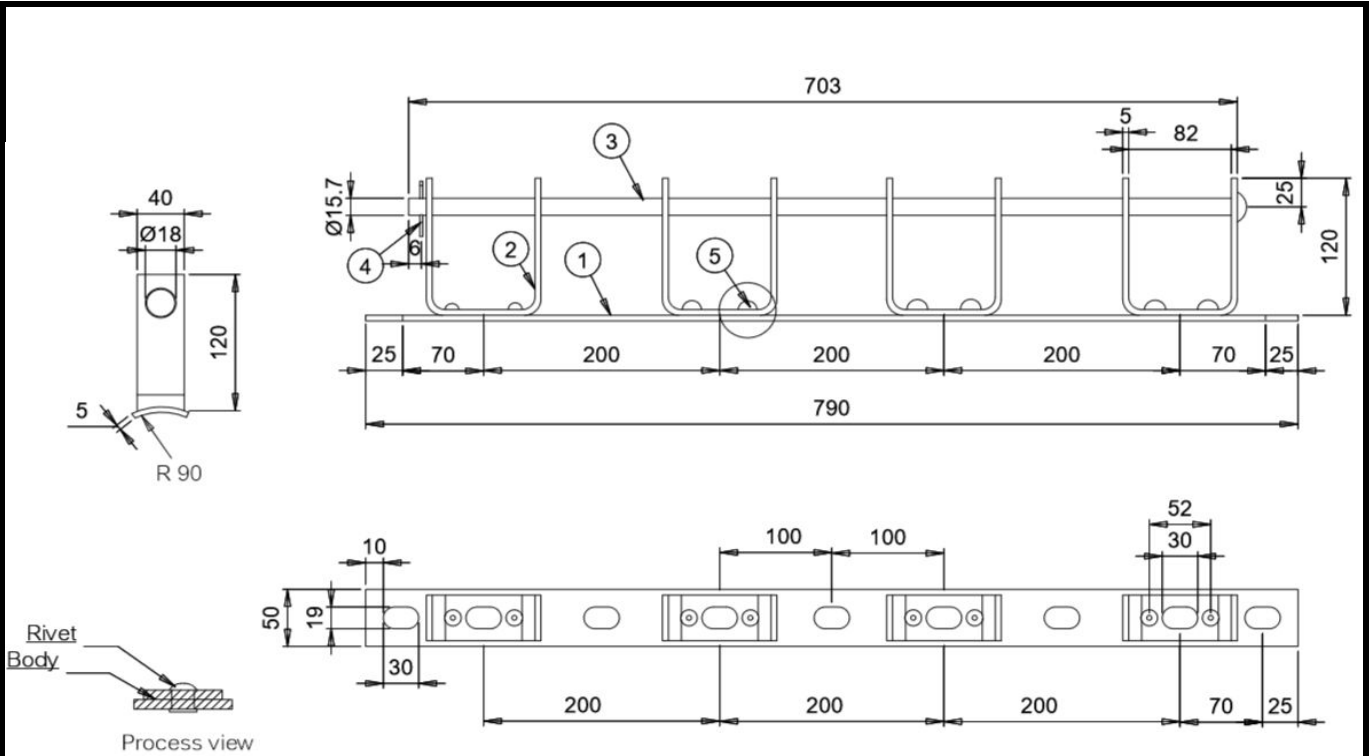

- PEA Material No. 1030130002
- Material of Body Flat Iron 50x5 mm.
- Material of Bow Flat Iron 40x5 mm.
- Bolt  $\varnothing$  15.7 mm.
- Cotton Pin 4x30 mm.
- Rivet 10x26 mm.
- Surface Finishing Hot Dip Galvanized according to PEA standard.



|   |  |  |
|---|--|--|
|  | บริษัท เอี่ยมพงศ์พัฒนา จำกัด<br>IAMPONG DEVELOPMENT CO.,LTD                                      | Approved by<br> |
| PEA Material No.<br><br>1030130002  | <b>แร็ค 4x200 มม.(4x8") แบบหลังยื่น</b><br><b>Rack, Secondary, Medium Pressed Steel 4x200mm.</b> | Managing Director<br><br>Date : 12/2/63  |

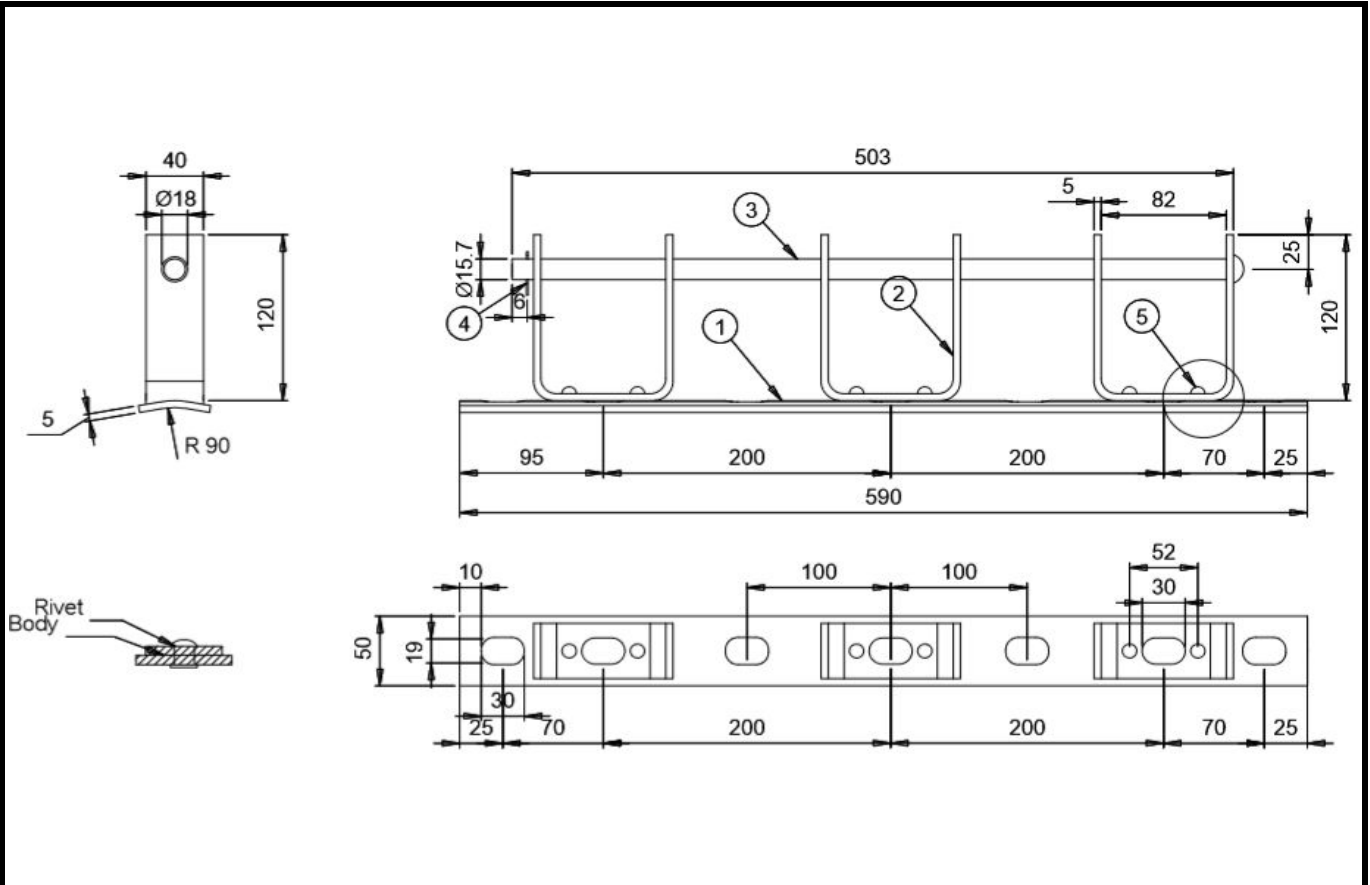

- PEA Material No. 1030130001
- Material of Body Flat Iron 50x5 mm.
- Material of Bow Flat Iron 40x5 mm.
- Bolt  $\varnothing$  15.7 mm.
- Cotton Pin 4x30 mm.
- Rivet 10x26 mm.
- Surface Finishing Hot Dip Galvanized according to PEA standard.



|   |   |  |  |
|---|---|--|--|
|  | บริษัท เอี่ยมพงศ์พัฒนา จำกัด<br>IAMPONG DEVELOPMENT CO.,LTD |  | Approved by<br> |
|   | PEA Material No.<br>1030130001                              | <b>แร็ค 3x200 มม.(3x8") แบบหลังยื่น</b><br><b>Rack, Secondary, Medium Pressed Steel 3x200mm.</b> |  |